



Republic

R E P U B L I C
Blower Systems®

Direct Drive

Tubeaxial Fans

Republic offers a complete line of high flow direct drive tubeaxial fans. Designed for use in low to medium pressure ducted applications the Republic Direct Drive Tubeaxial Fans may be mounted either horizontally or vertically. They are generally used for removal of contaminated air or hot air found in industrial applications; but can also be used to supply air through duct work for cooling or pressurizing interior spaces. The low-maintenance, oil-free design provides continuous, dependable service.



Standard Features Include:

- ▲ Spark resistant, cast aluminum propellers or heavy-duty steel propellers
- ▲ Statically balanced to assure smooth operation
- ▲ Shafts that are turned, ground, and polished or stainless steel
- ▲ Continuously-welded drum seam



Applications:

- ▲ Air purge ventilation
- ▲ Commercial fryer exhaust
- ▲ Compressor room exhaust
- ▲ Dust hood exhaust
- ▲ Fume exhaust
- ▲ Glass cooling
- ▲ Hazmat room exhaust
- ▲ Paint spray booth
- ▲ Welding booth
- ▲ Wood molding machinery
- ▲ Incinerators
- ▲ Powder booths

LOW PRESSURE PERFORMANCE

Model	Fan BHP		Standard Air Delivery (CFM)								RPM	Motor HP	Approx. Weight (lbs.)
	Free Air	Max.	Free Air	Static Pressure (Inches of Water)									
				1/8"	1/4"	3/8"	1/2"	5/8"	3/4"	1"			
RTAF-12	0.054	0.062	1223	936							1725	1/20	45
	0.106	0.121	1461	1250							1725	1/8	50
	0.174	0.196	1615	1518	1390	1235	995				3450	1/4	50
RTAF-16	0.058	0.059	1696	766							1725	1/20*	75
	0.101	0.108	2050	1600							1725	1/8*	75
	0.087	0.098	1968	1280							1140	1/12*	75
	0.264	0.298	2870	2526	1975						1725	1/4	75
RTAF-20	0.09	0.09	2740	1565							1140	1/12*	90
	0.10	0.12	3225	2165							860	1/8*	95
	0.13	0.15	3450	2500							860	1/6*	100
	0.16	0.18	3420	2695							1140	1/6*	90
	0.22	0.26	4165	3500	1870						1725	1/4	90
	0.27	0.28	3985	3360	2430						1725	1/4	90
	0.30	0.36	4570	4000	2700						1140	1/3*	115
	0.52	0.57	5055	4550	4080	3510					1725	1/2	95
	0.79	0.90	6350	5970	5510	4920	4040				1725	3/4	110
0.99	1.17	6775	6430	6040	5530	4730				1725	1	115	
RTAF-24	0.07	0.08	3295	1546							1140	1/12*	110
	0.14	0.15	4010	2850							1140	1/6*	110
	0.13	0.15	4045	2830							860	1/8*	120
	0.19	0.22	4990	3970							860	1/4	120
	0.23	0.24	4830	3800	2500						1725	1/4	110
	0.28	0.31	5185	4290	3200						1140	1/4	115
	0.26	0.35	5490	4605	2690						860	1/3*	145
	0.45	0.50	5940	5180	4370	3450					1725	1/2	110
	0.45	0.52	6600	5860	4970						1140	1/2	125
	0.64	0.85	7385	6860	6030	4970					1140	3/4*	140
	1.02	1.13	7935	7400	6800	6175	5480	4590	3295		1725	1	130
1.61	1.86	10110	9690	9180	8660	8100	7370	5900		1725	2	150	
RTAF-30	0.21	0.24	6190	4620	2210						860	1/4	145
	0.27	0.28	6635	4940							1725	1/4	135
	0.46	0.51	7735	6530	5320	3910					1725	1/2	145
	0.38	0.45	7815	5950							650	1/2	165
	0.41	0.45	7590	6180	4430						1140	1/2	150
	0.37	0.45	8340	7050	4750						860	1/2	195
	0.49	0.56	8175	7040	5750						1140	1/2	145
	0.57	0.67	9535	8350	5820						860	3/4	240
	0.81	0.97	10080	8850	6910	4210					860	1	245
	0.92	1.12	11310	10400	9350	7900	5600				1140	1	165
	1.37	1.5	11340	10500	9510	8390	7190	5920	4100		1725	1 1/2	190
	1.27	1.49	12430	11580	10500	8700	5520				1140	1 1/2	215
	1.78	2.02	11890	11100	10300	9410	8530	7530	4730		1715	2	190
	1.89	2.27	13320	12400	11300	9960	8200	6000			1140	2	235
2.77	3.34	16070	15420	14570	14000	13150	12200	11120	7500	1725	3	225	
4.65	5.43	19180	18550	18000	17450	16750	16000	15000	11800	1752	5	250	

MEDIUM PRESSURE PERFORMANCE

Model	Standard Air Delivery (CFM)											RPM	Motor HP	Approx. Weight (lbs.)
	Free Air	Static Pressure (Inches of Water)												
		1/4"	1/2"	3/4"	1"	1 1/4"	1 1/2"	1 3/4"	2"	2 1/4"	2 1/2"			
RTAF-12	1900	1800	1650	1450	1150	500						3450	1/3	85
	2150	2100	2050	2000	1900	1800	1750	1650	1500			3450	1	95
RTAF-16	3350	3200	3050	2850	2650	2400	2050	1550	1350			3450	1	105
	5400	5350	5100	4900	4700	4500	4250	3650	3500			3450	2	120
	6300	6150	5950	5750	5550	5300	5000	4750	4300			3450	3	135
RTAF-20	6500	6250	6000	5750	5500	5200	4900	4550	4150	3600	2900	3450	2	125
	8300	8000	7700	7500	7200	6950	6700	6450	6100	5600	5000	3450	3	160
	10300	10100	9800	9500	9300	9000	8700	8400	8100	7600	7100	3450	5	165
RTAF-24	9000	8100	7200	3900	2200							1725	1	230
	10000	9600	9200	8700	8200	7700	7200	6600	6000	5400	4500	3450	3	250
	13000	12600	12100	11600	11100	10500	9900	9300	8600	7900	6900	3450	5	255
	15300	14900	14500	14100	13700	13300	12900	12400	11900	11300	10700	3450	7.5	265
RTAF-30	12000	11500	11000	10400	9600	8600	7500	5400	4600			1725	3	350
	15400	14900	14300	13700	13000	12200	11200	9600	6000			1725	5	360
	19600	19000	18400	17800	17000	16200	15400	14000				1725	7.5	270

*Minimum 1/4 HP motors are usually furnished where ratings for 1/8 HP and less are specified; the next higher HP rating is usually furnished in place of 1/3, 3/4, and some 1 1/2 HP ratings.

DIMENSIONS

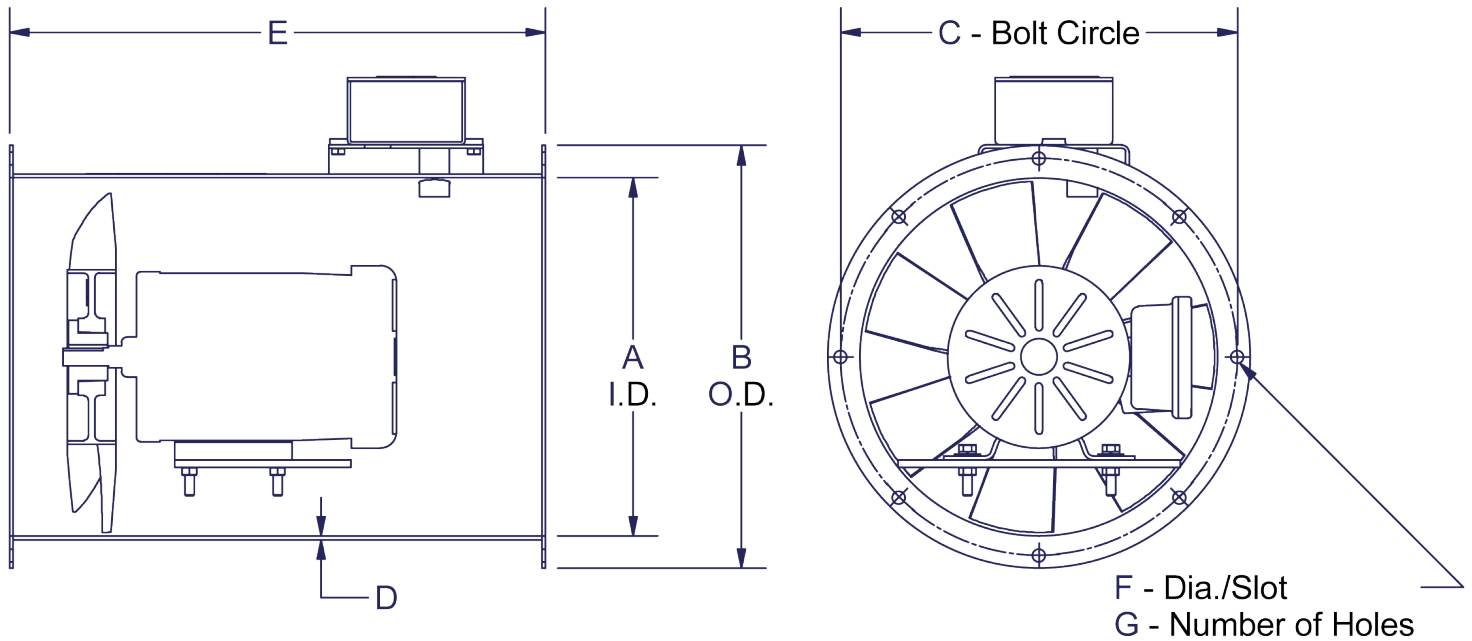

Model	Motor (HP)	TEFC Motor Frame	Dimensions						
			A	B	C	D	E	F	G
RTAF-12	1	143T	12.19	14.38	13.5	11 ga	18.27	0.44	8
RTAF-16	1	143T	16.25	18	17.25	11 ga	22.24	0.44	4
	2	145T	16.25	18	17.25	11 ga	22.24	0.44	4
RTAF-20	3	182T	16.25	18	17.25	11 ga	22.24	0.44	4
	2	145T	19.94	23	22.81	11 ga	22.24	0.5 x 1	4
	3	182T	19.94	23	22.81	11 ga	22.24	0.5 x 1	4
RTAF-24	5	184T	19.94	23	22.81	11 ga	22.24	0.5 x 1	4
	1	143T	24.25	27	25.88	11 ga	22.24	0.5 x 1	8
	3	182T	24.25	27	25.88	11 ga	22.24	0.5 x 1	8
	5	184TC	24.25	27	25.88	11 ga	22.24	0.5 x 1	8
RTAF-30	7.5	213TC	24.25	27	25.88	11 ga	22.24	0.5 x 1	8
	3	182T	30.25	33	31.80	11 ga	22.24	0.5 x 1	8
	5	184TC	30.25	33	31.80	11 ga	22.24	0.5 x 1	8
	7.5	213TC	30.25	33	31.80	11 ga	22.24	0.5 x 1	8